



GERBER

VITREOUS CHINA
TOILET
21-900

LAVATORIES

TOILETS

BIDETS / URINALS

CAST IRON

MAXWELL® 1.28 Round Front Toilet

10" Rough-in

Features:

- 1.28 gpf/4.8 Lpf high efficiency two-piece toilet
- Round Front bowl
- Dual-fed siphon jet
- Pilot fill valve
- 3" flush valve
- 2" glazed trapway
- Color matched front tank lever (white only)
- Available in White and Biscuit
- 2 bolt caps



Dimensions:

- Height 28 5/8"
- Width 17 1/4"
- Depth 24 7/8"
- Rough-in 10"
- Water Surface from Rim 6"
- Trapway 2"
- Water Surface 9 1/8" x 7"
- Water Seal 2 1/4"
- Shipping Weight 69.5 lbs

Specifications: Bowl—#21-952 Round Front Bowl Tank—#28-995
Seat not included

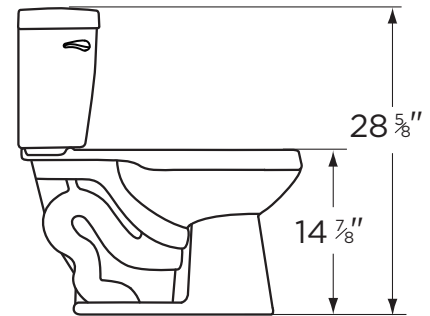
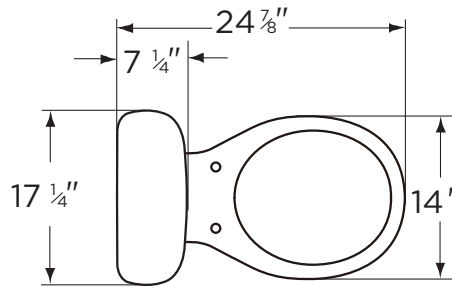

THIS FIXTURE QUALIFIES
ACCORDING TO ASME TEST
PROCEDURES AS A HIGH-
EFFICIENCY WATER CLOSET
WITH AN AVERAGE CONSUMPTION
OF 1.28 gpf (4.8 Lpf) OR LESS.

HIGH EFFICIENCY TOILET
HET

www.gerberonline.com

Job Name	
Date	
Model Specified	
Quantity	
Customer	
Contractor	
Architect/engineer	



GERBER

1.28 gpf (4.8 Lpf) MAXWELL® 1.28 TOILET

21-900

Round Front, 10" Rough-in

(Bowl 21-952 with Tank 28-995)

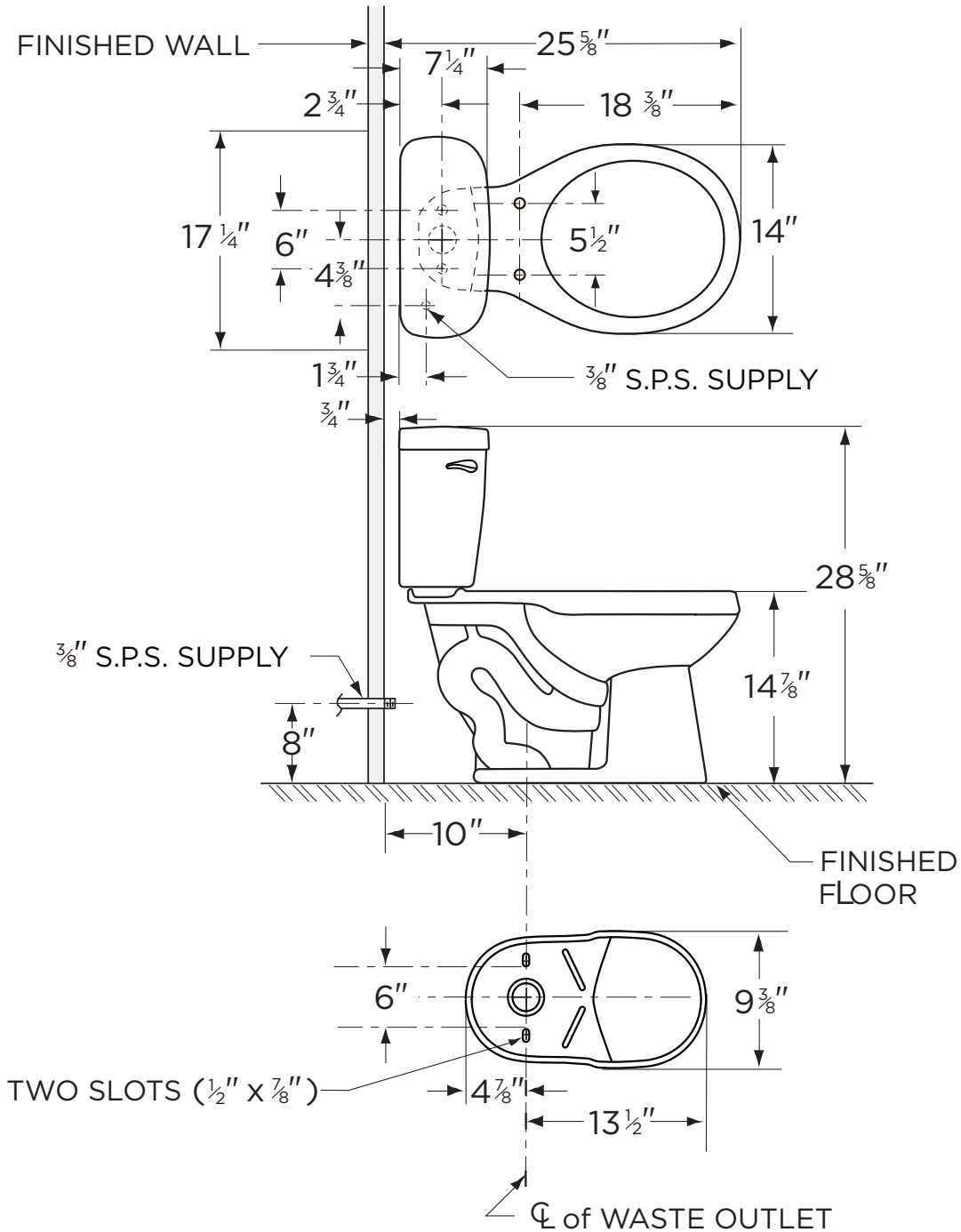

NOTES:

All dimensions are in inches.

Illustrations may not be drawn to scale.

IMPORTANT:

Dimensions of fixtures are nominal and may vary within the range of tolerances established by ASME Standard A 112.19.2.

THIS FIXTURE QUALIFIES ACCORDING TO ASME TEST PROCEDURES AS A HIGH-EFFICIENCY WATER CLOSET WITH AN AVERAGE CONSUMPTION OF 1.28 gpf (4.8 Lpf) OR LESS.